

Enhanced Current Mode PWM Controller

CS51021A

The CS51021A Fixed Frequency PWM Current Mode Controller provides all necessary features required for AC–DC or DC–DC primary side control. Several features are included eliminating the additional components needed to implement them externally. In addition to low startup current (75 μ A) and high frequency operation capability, the CS51021A includes overvoltage and undervoltage monitoring, externally programmable dual threshold overcurrent protection, current sense leading edge blanking, current slope compensation, accurate duty cycle control and an externally available 5.0 V reference. The CS51021A features bidirectional synchronization capability. The CS51021A is available in a 16 lead narrow body SOIC package.

| Device | Sleep/Synch | V _{CC} Start/Stop |
|----------|-------------|----------------------------|
| CS51021A | Synch | 8.25 V/7.7 V |

Features

- 75 μ A Max. Startup Current
- Fixed Frequency Current Mode Control
- 1.0 MHz Switching Frequency
- Undervoltage Protection Monitor
- Overvoltage Protection Monitor with Programmable Hysteresis
- Programmable Dual Threshold Overcurrent Protection with Delayed Restart
- Programmable Soft Start
- Accurate Maximum Duty Cycle Limit
- Programmable Slope Compensation
- Leading Edge Current Sense Blanking
- 1.0 A Sink/Source Gate Drive
- Bidirectional Synchronization
- 50 ns PWM Propagation Delay
- These Devices are Pb–Free and are RoHS Compliant

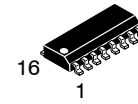

SOIC–16
 D SUFFIX
 CASE 751B–05

PIN CONNECTIONS AND MARKING DIAGRAM

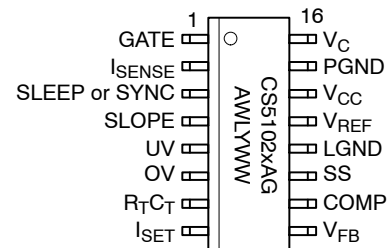

- x = Specific Device Code
- A = Assembly Location
- WL = Wafer Lot
- Y = Year
- WW = Work Week
- G = Pb–Free Package

ORDERING INFORMATION

See detailed ordering and shipping information in the package dimensions section on page 9 of this data sheet.

CS51021A

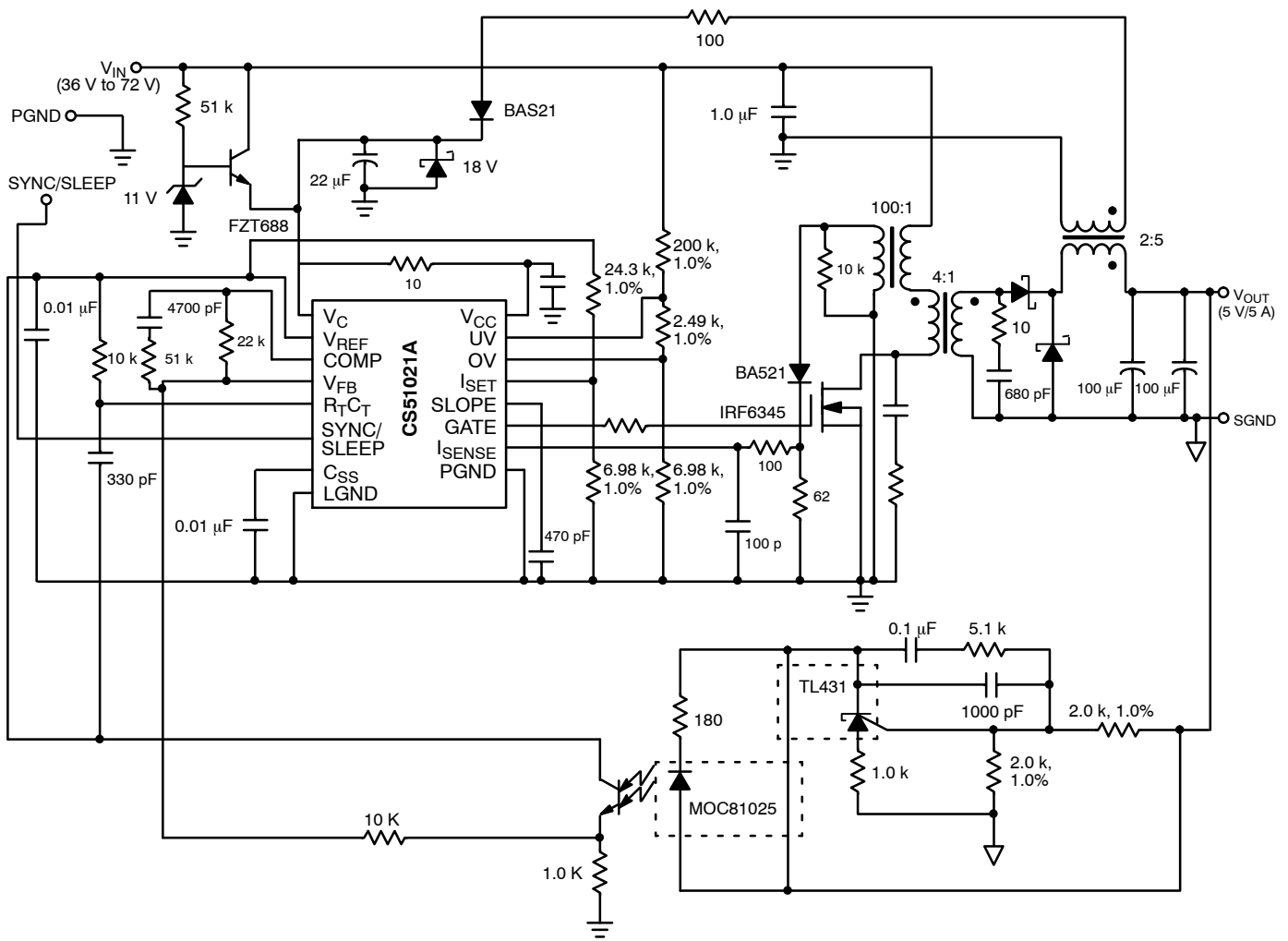

Figure 1. Typical Application Diagram, 36–72 V to 5.0 V, 5.0 A DC–DC Converter

MAXIMUM RATINGS*

| Rating | Value | Unit |
|---|------------------------------------|--------------------|
| Power Supply Voltage, V_{CC} | -0.3, 20 | V |
| Driver Supply Voltage, V_C | -0.3, 20 | V |
| SYNC, SLEEP, $R_T C_T$, SOFT-START, V_{FB} , SLOPE, I_{SENSE} , UV, OV, I_{SET} (Logic Pins) | 0.25 to V_{REF} | V |
| Peak GATE Output Current | 1.0 | A |
| Steady State Output Current | ± 0.2 | A |
| Operating Junction Temperature, T_J | 150 | $^{\circ}\text{C}$ |
| Storage Temperature Range, T_S | -65 to +150 | $^{\circ}\text{C}$ |
| ESD (Human Body Model) | 2.0 | kV |
| Lead Temperature Soldering: | Reflow: (SMD styles only) (Note 1) | 230 peak |

Stresses exceeding those listed in the Maximum Ratings table may damage the device. If any of these limits are exceeded, device functionality should not be assumed, damage may occur and reliability may be affected.

*The maximum package power dissipation must be observed.

1. 60 second maximum above 183 $^{\circ}\text{C}$.

CS51021A

ELECTRICAL CHARACTERISTICS (Unless otherwise stated, specifications apply for $-40^{\circ}\text{C} < T_A < 85^{\circ}\text{C}$, $-40^{\circ}\text{C} < T_J < 150^{\circ}\text{C}$, $3.0\text{ V} < V_C < 20\text{ V}$, $8.2\text{ V} < V_{CC} < 20\text{ V}$, $R_T = 12\text{ k}\Omega$, $C_T = 390\text{ pF}$)

| Characteristic | Test Conditions | Min | Typ | Max | Unit |
|----------------|-----------------|-----|-----|-----|------|
|----------------|-----------------|-----|-----|-----|------|

Under Voltage Lockout

| | | | | | |
|--------------------|---------------------------------|------|------|------|---------------|
| START Threshold | - | 7.95 | 8.25 | 8.8 | V |
| STOP Threshold | - | 7.4 | 7.7 | 8.2 | V |
| Hysteresis | - | 0.50 | 0.75 | 1.00 | V |
| I_{CC} @ Startup | $V_{CC} < UV_{START}$ Threshold | - | 40 | 75 | μA |
| I_{CC} Operating | - | - | 7.0 | 9.0 | mA |
| I_{CC} Operating | Includes 1.0 nF Load | - | 7.0 | 12 | mA |

Voltage Reference

| | | | | | |
|------------------|--|-----------------------|-----------------------|------------------------|---------------|
| Initial Accuracy | $T_A = 25^{\circ}\text{C}$, $I_{REF} = 2.0\text{ mA}$, $V_{CC} = 14\text{ V}$, (Note 2) | 4.95 | 5.0 | 5.05 | V |
| Total Accuracy | $1.0\text{ mA} < I_{REF} < 10\text{ mA}$ | 4.9 | 5.0 | 5.15 | V |
| Line Regulation | $8.2\text{ V} < V_{CC} < 18\text{ V}$, $I_{REF} = 2.0\text{ mA}$ | - | 6.0 | 20 | mV |
| Load Regulation | $1.0\text{ mA} < I_{REF} < 10\text{ mA}$ | - | 6.0 | 15 | mV |
| NOISE Voltage | (Note 2) | - | 50 | - | μV |
| OP Life Shift | $T = 1000\text{ Hours}$, (Note 2) | - | 4.0 | 20 | mV |
| FAULT Voltage | Force V_{REF} | $0.90 \times V_{REF}$ | $0.93 \times V_{REF}$ | $0.95 \times V_{REF}$ | V |
| OK Voltage | Force V_{REF} | $0.94 \times V_{REF}$ | $0.96 \times V_{REF}$ | $0.985 \times V_{REF}$ | V |
| OK Hysteresis | Force V_{REF} | 75 | 165 | 250 | mV |
| Current Limit | Force V_{REF} | -20 | - | - | mA |

Error Amplifier

| | | | | | |
|-----------------------------|---|-------|-------|-------|---------------|
| Initial Accuracy | $T_A = 25^{\circ}\text{C}$, $I_{REF} = 2.0\text{ mA}$, $V_{CC} = 14\text{ V}$, $V_{FB} = \text{COMP}$, (Note 2) | 2.465 | 2.515 | 2.565 | V |
| Reference Voltage | $V_{FB} = \text{COMP}$ | 2.440 | 2.515 | 2.590 | V |
| V_{FB} Leakage Current | $V_{FB} = 0\text{ V}$ | - | -0.2 | -2.0 | μA |
| Open Loop Gain | $1.4\text{ V} < \text{COMP} < 4.0\text{ V}$, (Note 2) | 60 | 90 | - | dB |
| Unity Gain Bandwidth | (Note 2) | 1.5 | 2.5 | - | MHz |
| COMP Sink Current | $\text{COMP} = 1.5\text{ V}$, $V_{FB} = 2.7\text{ V}$ | 2.0 | 6.0 | - | mA |
| COMP Source Current | $\text{COMP} = 1.5\text{ V}$, $V_{FB} = 2.3\text{ V}$ | -0.2 | -0.5 | - | mA |
| COMP High Voltage | $V_{FB} = 2.3\text{ V}$ | 4.35 | 4.8 | 5.0 | V |
| COMP Low Voltage | $V_{FB} = 2.7\text{ V}$ | 0.4 | 0.8 | 1.2 | V |
| PS Ripple Rejection | $\text{FREQ} = 120\text{ Hz}$, (Note 2) | 60 | 85 | - | dB |
| SS Clamp, V_{COMP} | $V_{SS} = 2.5\text{ V}$, $V_{FB} = 0\text{ V}$, $I_{\text{SET}} = 2.0\text{ V}$ | 2.4 | 2.5 | 2.6 | V |
| $I_{\text{LIM(SET)}}$ Clamp | (Note 2) | 0.95 | 1.0 | 1.15 | V |

2. Guaranteed by design, not 100% tested in production.

CS51021A

ELECTRICAL CHARACTERISTICS (Unless otherwise stated, specifications apply for $-40^{\circ}\text{C} < T_A < 85^{\circ}\text{C}$, $-40^{\circ}\text{C} < T_J < 150^{\circ}\text{C}$, $3.0\text{ V} < V_C < 20\text{ V}$, $8.2\text{ V} < V_{CC} < 20\text{ V}$, $R_T = 12\text{ k}\Omega$, $C_T = 390\text{ pF}$)

| Characteristic | Test Conditions | Min | Typ | Max | Unit |
|----------------|-----------------|-----|-----|-----|------|
|----------------|-----------------|-----|-----|-----|------|

Oscillator

| | | | | | |
|-----------------------------|---|-------|-----|-------|---------------|
| Accuracy | $R_T = 12\text{ k}$, $C_T = 390\text{ pF}$ | 230 | 255 | 280 | kHz |
| Voltage Stability | Delta Frequency $8.2\text{ V} < V_{CC} < 20\text{ V}$ | – | 2.0 | 3.0 | % |
| Temperature Stability | $T_{MIN} < T_A < T_{MAX}$, (Note 3) | – | 8.0 | – | % |
| Min Charge & Discharge Time | (Note 3) | 0.333 | – | – | μs |
| Duty Cycle Accuracy | $R_T = 12\text{ k}$, $C_T = 390\text{ pF}$ | 70 | 77 | 83 | % |
| Peak Voltage | (Note 3) | – | 3.0 | – | V |
| Valley Voltage | (Note 3) | – | 1.5 | – | V |
| Valley Clamp Voltage | 10 k Resistor to ground on $R_T C_T$ | 1.2 | 1.4 | 1.6 | V |
| Discharge Current | – | 0.8 | 1.0 | 1.2 | mA |
| Discharge Current | $T_A = 25^{\circ}\text{C}$, Note 3 | 0.925 | 1.0 | 1.075 | mA |

Synchronization (CS51021A/3A)

| | | | | | |
|----------------------|-------------------------------------|------|-----|-----|------------|
| Input Threshold | – | 1.0 | 1.5 | 2.7 | V |
| Output Pulsewidth | – | 160 | 260 | 400 | ns |
| Output High Voltage | $I_{SYNC} = 100\text{ }\mu\text{A}$ | 3.5 | 4.3 | 4.8 | V |
| Input Resistance | (Note 3) | 35 | 70 | 140 | k Ω |
| Drive Delay | SYNC to GATE RESET | 80 | 120 | 150 | ns |
| Output Drive Current | 1.0 k Load | 1.25 | 2.0 | 3.5 | mA |

SLEEP (CS51022A/4A)

| | | | | | |
|-----------------------|----------------------------|-----|-----|-----|---------------|
| SLEEP Input Threshold | Active High | 1.0 | 1.5 | 2.7 | V |
| SLEEP Input Current | $V_{SLEEP} = 4.0\text{ V}$ | 11 | 25 | 46 | μA |
| I_{CC} @ SLEEP | $V_{CC} \leq 15\text{ V}$ | – | 50 | 100 | μA |

GATE Driver

| | | | | | |
|--------------------|--|----|------|-----|---------------|
| HIGH Voltage | Measure $V_C - \text{GATE}$, $V_C = 10\text{ V}$, 150 mA Load | – | 1.5 | 2.2 | V |
| LOW Voltage | Measure $\text{GATE} - \text{PGND}$, 150 mA SINK | – | 1.2 | 1.5 | V |
| HIGH Voltage Clamp | $V_C = 20\text{ V}$, 1.0 nF | 11 | 13.5 | 16 | V |
| LOW Voltage Clamp | Measured at 10 mA Output Current | – | 0.6 | 0.8 | V |
| Peak Current | $V_C = 20\text{ V}$, 1.0 nF, (Note 3) | – | 1.0 | – | A |
| UVL Leakage | $V_C = 20\text{ V}$ measured at 0 V | – | –1.0 | –50 | μA |
| RISE Time | Load = 1.0 nF, $1.0\text{ V} < \text{GATE} < 9.0\text{ V}$, $V_C = 20\text{ V}$, $T_A = 25^{\circ}\text{C}$ | – | 60 | 100 | ns |
| FALL Time | Load = 1.0 nF, $9.0\text{ V} > \text{GATE} > 1.0\text{ V}$, $V_C = 20\text{ V}$ | – | 15 | 40 | ns |

SLOPE Compensation

| | | | | | |
|-------------------|--|-------|-------|-------|---------------|
| Charge Current | SLOPE = 2.0 V | –63 | –53 | –43 | μA |
| COMP Gain | Fraction of slope voltage added to I_{SENSE} , (Note 3) | 0.095 | 0.100 | 0.105 | V/V |
| Discharge Voltage | SYNC = 0 V | – | 0.1 | 0.2 | V |

3. Guaranteed by design, not 100% tested in production.

CS51021A

ELECTRICAL CHARACTERISTICS (Unless otherwise stated, specifications apply for $-40^{\circ}\text{C} < T_A < 85^{\circ}\text{C}$, $-40^{\circ}\text{C} < T_J < 150^{\circ}\text{C}$, $3.0\text{ V} < V_C < 20\text{ V}$, $8.2\text{ V} < V_{CC} < 20\text{ V}$, $R_T = 12\text{ k}\Omega$, $C_T = 390\text{ pF}$)

| Characteristic | Test Conditions | Min | Typ | Max | Unit |
|-------------------------------|------------------|------|------|------|------------------|
| Current Sense | | | | | |
| OFFSET Voltage | (Note 4) | 0.09 | 0.10 | 0.11 | V |
| Blanking Time | – | – | 55 | 160 | ns |
| Blanking Disable Voltage | Adjust V_{FB} | 1.8 | 2.0 | 2.2 | V |
| Second Current Threshold Gain | – | 1.21 | 1.33 | 1.45 | V/V |
| I_{SENSE} Input Resistance | – | – | 5.0 | – | $\text{k}\Omega$ |
| Minimum On Time | GATE High to Low | 30 | 70 | 110 | ns |
| Gain | (Note 4) | 0.78 | 0.80 | 0.82 | V/V |

OV & UV Voltage Monitors

| | | | | | |
|-----------------------|---|------|-------|------|---------------|
| OV Monitor Threshold | – | 2.4 | 2.5 | 2.6 | V |
| OV Hysteresis Current | – | –10 | –12.5 | –15 | μA |
| UV Monitor Threshold | – | 1.38 | 1.45 | 1.52 | V |
| UV Monitor Hysteresis | – | 25 | 75 | 100 | mV |

SOFT START (SS)

| | | | | | |
|-----------------------------|------------|------|------|------|---------------|
| Charge Current | SS = 2.0 V | –70 | –55 | –40 | μA |
| Discharge Current | SS = 2.0 V | 250 | 1000 | – | μA |
| Charge Voltage, V_{SS} | – | 4.4 | 4.7 | 5.0 | V |
| Discharge Voltage, V_{SS} | – | 0.25 | 0.27 | 0.30 | V |

4. Guaranteed by design, not 100% tested in production.

PACKAGE PIN DESCRIPTION

| PIN # | PIN SYMBOL | FUNCTION |
|--------------------------|-------------|--|
| 16 Lead SO Narrow | | |
| 1 | GATE | External power switch driver with 1.0 A peak capability. |
| 2 | I_{SENSE} | Current sense amplifier input. |
| 3 | SYNC | Bi-directional synchronization. Locks to the highest frequency. |
| 4 | SLOPE | Additional slope to the current sense signal. Internal current source charges the external capacitor. |
| 5 | UV | Undervoltage protection monitor. |
| 6 | OV | Overvoltage protection monitor. |
| 7 | $R_T C_T$ | Timing resistor R_T and capacitor C_T determine oscillator frequency and maximum duty cycle, D_{MAX} . |
| 8 | I_{SET} | Voltage at this pin sets pulse-by-pulse overcurrent threshold, and second threshold (1.33 times higher) with Soft Start retrigger (hiccup mode). |
| 9 | V_{FB} | Feedback voltage input. Connected to the error amplifier inverting input. |
| 10 | COMP | Error amplifier output. Frequency compensation network is usually connected between COMP and V_{FB} pins. |
| 11 | SS | Charging external capacitor restricts error amplifier output voltage during the start or fault conditions (hiccup). |
| 12 | LGND | Logic ground. |
| 13 | V_{REF} | 5.0 V reference voltage output. |
| 14 | V_{CC} | Logic supply voltage. |
| 15 | PGND | Output power stage ground connection. |
| 16 | V_C | Output power stage supply voltage. |

CS51021A

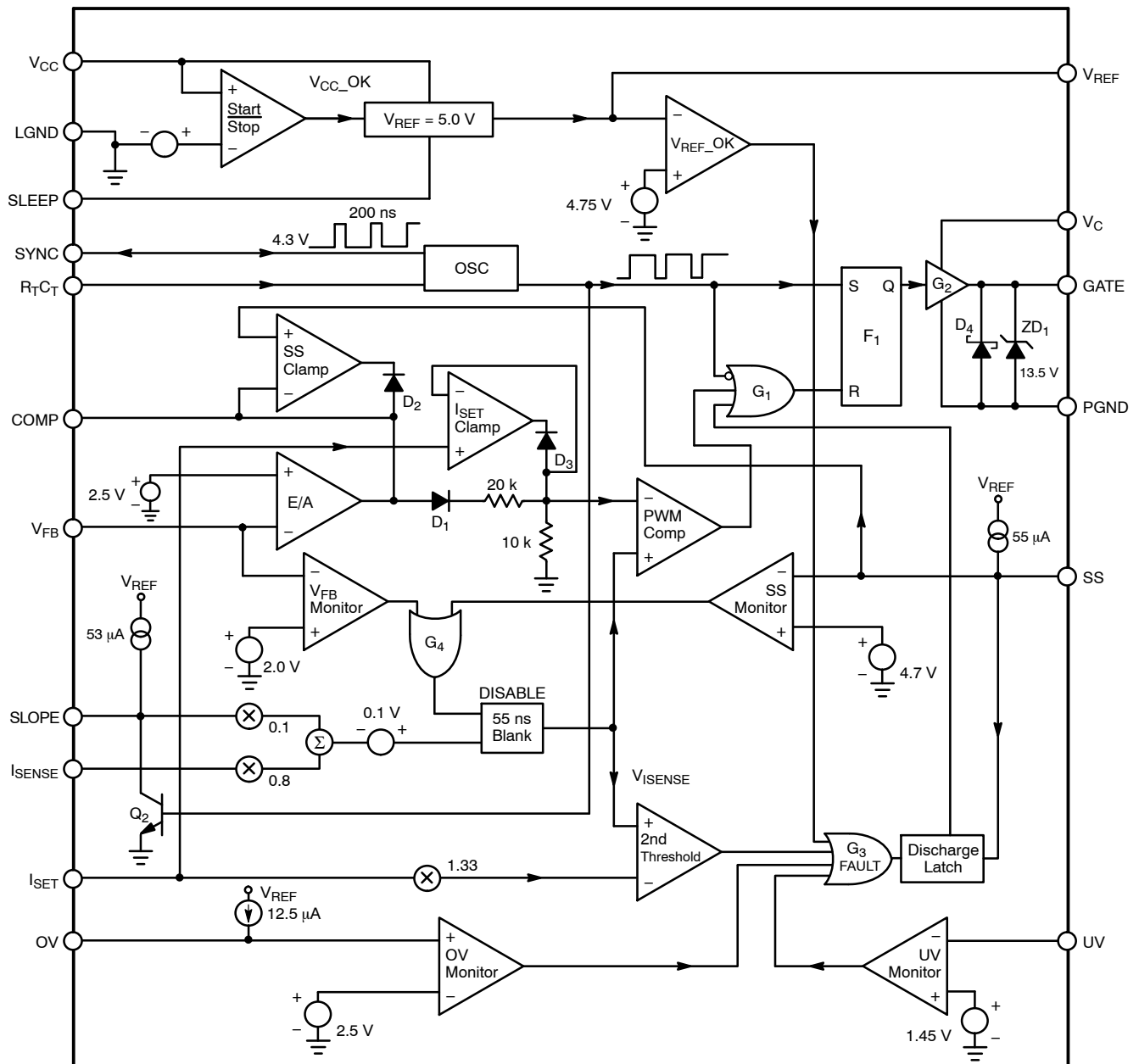

Figure 2. Block Diagram

CIRCUIT DESCRIPTION

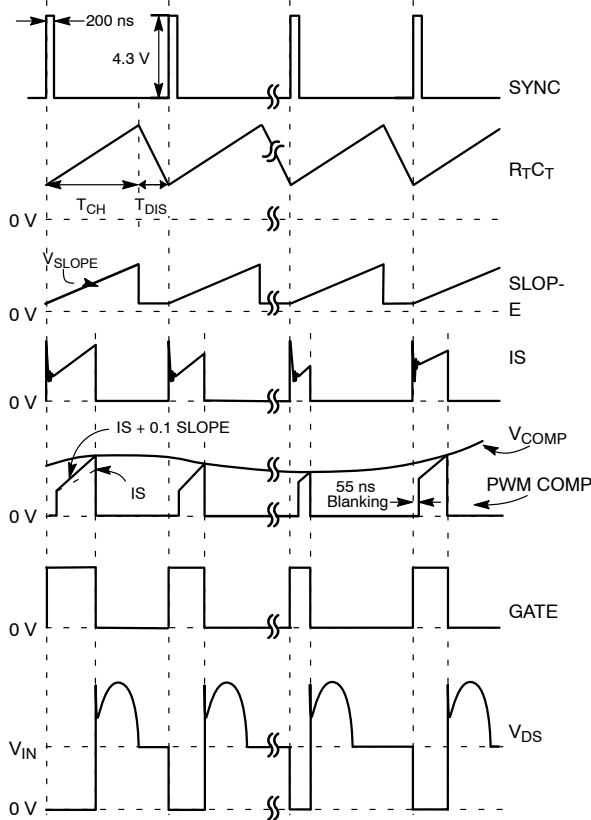

Figure 3. Typical Waveforms

THEORY OF OPERATION

Powering the IC

The IC has two supply and two ground pins. V_C and PGND pins provide high speed power drive for the external power switch. V_{CC} and LGND pins power the control portion of the IC. The internal logic monitors the supply voltage, V_{CC} . During abnormal operating conditions, the output is held low. The CS51021A requires only 75 μA of startup current.

Voltage Feedback

The output voltage is monitored via the V_{FB} pin and is compared with the internal 2.5 V reference. The error amplifier output minus one diode drop is divided by 3 and connected to the negative input of the PWM comparator. The positive input of the PWM comparator is connected to the modified current sense signal. The oscillator turns the external power switch on at the beginning of each cycle. When current sense ramp voltage exceeds the reference side of PWM comparator, the output stage latches off. It is turned on again at the beginning of the next oscillator cycle.

Current Sense and Protection

The current is monitored at the I_{SENSE} pin. The CS51021A has leading edge blanking circuitry that ignores the first 55 ns of each switching period. Blanking is disabled when V_{FB} is less than 2.0 V so that the minimum on-time of the controller does not have an additional 55 ns of delay time during fault conditions. For the remaining portion of the switching period, the current sense signal, combined with a fraction of the slope compensation voltage, is applied to the positive input of the PWM comparator where it is compared with the divided by three error amplifier output voltage. The pulse-by-pulse overcurrent protection threshold is set by the voltage at the I_{SET} pin. This voltage is passed through the I_{SET} Clamp and appears at the non-inverting input of the PWM comparator, limiting its dynamic range according to the following formula:

$$\text{Overcurrent Threshold} = 0.8 \times V_{I(SENSE)} + 0.1 V + 0.1 V_{SLOPE}$$

where

$V_{I(SENSE)}$ is voltage at the I_{SENSE} pin.

and

V_{SLOPE} is voltage at the SLOPE pin.

During extreme overcurrent or short circuit conditions, the slope of the current sense signal will become much steeper than during normal operation. Due to loop propagation delay, the sensed signal will overshoot the pulse-by-pulse threshold eventually reaching the second overcurrent protection threshold which is 1.33 times higher than the first threshold and is described by the following equation:

$$\text{2nd Threshold} = 1.33 \times V_{I(SET)}$$

Exceeding the second threshold will reset the Soft Start capacitor C_{SS} and reinitiate the Soft Start sequence, repeating for as long as the fault condition persists.

Soft Start

During power up, when the output filter capacitor is discharged and the output voltage is low, the voltage across the Soft Start capacitor (V_{SS}) controls the duty cycle. An internal current source of 55 μA charges C_{SS} . The maximum error amplifier output voltage is clamped by the SS Clamp. When the Soft Start capacitor voltage exceeds the error amplifier output voltage, the feedback loop takes over the duty cycle control. The Soft Start time can be estimated with the following formula:

$$t_{SS} = 9 \times 10^4 \times C_{SS}$$

The Soft Start voltage, V_{SS} , charges and discharges between 0.25 V and 4.7 V.

Slope Compensation

DC-DC converters with current mode control require a current sense signal with slope compensation to avoid instability at duty cycles greater than 50%. Slope capacitor C_S is charged by an internal 53 μA current source and is discharged during the oscillator discharge time. The slope compensation voltage is divided by 10 and is added to the current sense voltage, $V_{I(\text{SENSE})}$. The signal applied to the input of the PWM comparator is a combination of these two voltages. The slope compensation, dV_{SLOPE}/dt , is calculated using the following formula:

$$\frac{dV_{\text{SLOPE}}}{dt} = 0.1 \times \frac{53 \mu\text{A}}{C_S}$$

It should be noted that internal capacitance of the IC will cause an error when determining slope compensation capacitance C_S . This error is typically small for large values of C_S , but increases as C_S becomes small and comparable to the internal capacitance. The effect is apparent as a reduction in charging current due to the need to charge the internal capacitance in parallel with C_S . Figure 4 shows a typical curve indicating this decrease in available charging current.

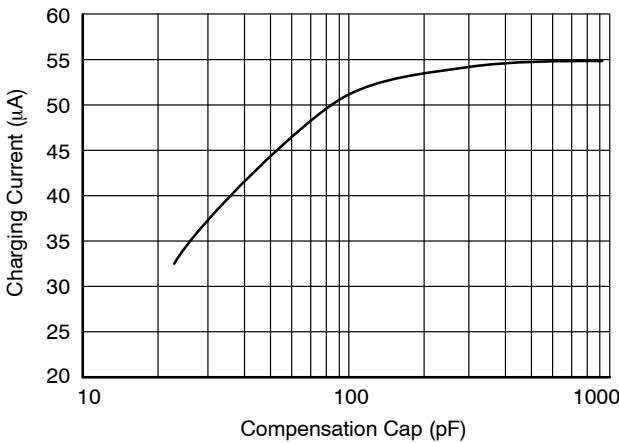

Figure 4. The Slope Compensation Pin Charge Current Reduces When a Small Capacitor Is Used.

Undervoltage (UV) and Overvoltage (OV) Monitor

Two independent comparators monitor OV and UV conditions. A string of three resistors is connected in series between the monitored voltage (usually the input voltage) and ground (see Figure 5). When voltage at the OV pin exceeds 2.5 V, an overvoltage condition is detected and GATE shuts down. An internal 12.5 μA current source turns on and feeds current into the external resistor, R_3 , creating a hysteresis determined by the value of this resistor (the higher the value, the greater the hysteresis). The hysteresis voltage of the OV monitor is determined by the following formula:

$$V_{\text{OV(HYST)}} = 12.5 \mu\text{A} \times R_3$$

where R_3 is a resistor connected from the OV pin to ground.

When the monitored voltage is low and the UV pin is less than 1.45 V, GATE shuts down. The UV pin has fixed 75 mV hysteresis.

Both OV and UV conditions are latched until the Soft Start capacitor is discharged. This way, every time a fault condition is detected the controller goes through the power up sequence.

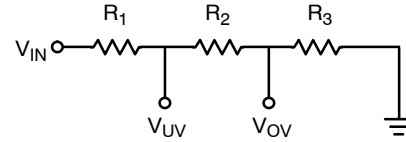

Figure 5. UV/OV Monitor Divider

To calculate the OV?UV resistor divider :

1. Solve for R_3 , based on OV hysteresis requirements.

$$R_3 = \frac{V_{\text{OV(HYST)}} \times 2.5 \text{ V}}{V_{\text{MAX}} \times 12.5 \mu\text{A}}$$

where $V_{\text{OV(HYST)}}$ is the desired amount of overvoltage hysteresis, and V_{MAX} is the input voltage at which the supply will shut down.

2. Find the total impedance of the divider.

$$R_{\text{TOT}} = R_1 + R_2 + R_3 = \frac{V_{\text{MAX}} \times R_3}{2.5}$$

3. Determine the value of R_2 from the UV threshold conditions.

$$R_2 = \frac{1.45 \times R_{\text{TOT}}}{V_{\text{MIN}}} - R_3$$

where V_{MIN} is the UV voltage at which the supply will shut down.

4. Calculate R_1 .

$$R_1 = R_{\text{TOT}} - R_2 - R_3$$

5. The undervoltage hysteresis is given by :

$$V_{\text{UV(HYST)}} = \frac{V_{\text{MIN}} \times 0.075}{1.45}$$

V_{REF} Monitor

The 5.0 V reference voltage is internally monitored to ensure that it remains within specifications. The monitor, which outputs a fault, can be tripped by two methods:

- If the reference voltage drops below 4.75 V
- If V_{CC} falls below the STOP threshold

As indicated in the block diagram, any fault causes the output to stop switching and begins the discharge of the Soft Start capacitor C_{SS} .

CS51021A

Synchronization

A bi-directional synchronization is provided to synchronize several controllers. When SYNC pins are connected together, the converters will lock to the highest switching frequency. The fastest controller becomes the master, producing a 4.3 V, 200 ns pulse train. Only one, the highest frequency SYNC signal, will appear on the SYNC line.

Sleep

The sleep input is an active high input. The CS51022A/4A is placed in sleep mode when SLEEP is driven high. In sleep mode, the controller and MOSFET are turned off. Connect to GND for normal operation. The sleep mode operates at $V_{CC} \leq 15$ V.

Oscillator and Duty Cycle Limit

The switching frequency is set by R_T and C_T connected to the $R_T C_T$ pin. C_T charges and discharges between 3.0 V and 1.5 V.

The maximum duty cycle is set by the ratio of the on time, t_{ON} , and the whole period, $T = t_{ON} + t_{OFF}$. Because the timing capacitor's discharge current is trimmed, the maximum duty cycle is well defined. It is determined by the ratio between the timing resistor R_T and the timing capacitor C_T . Refer to figures 6 and 7 to select appropriate values for R_T and C_T .

$$f_{SW} = \frac{1}{T_{SW}}; T_{SW} = t_{CH} + t_{DIS}$$

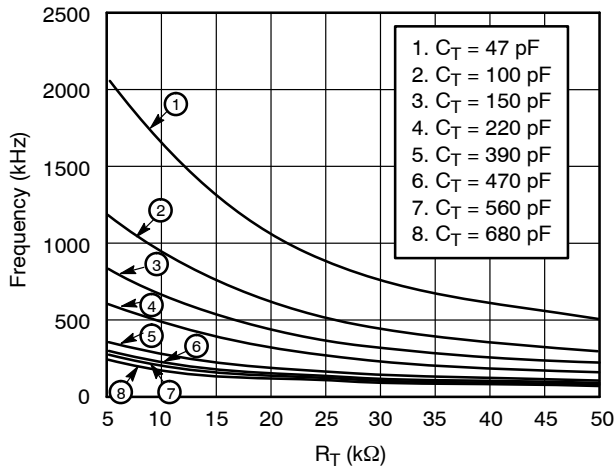

Figure 6. Frequency vs. R_T for Discrete Capacitor Values

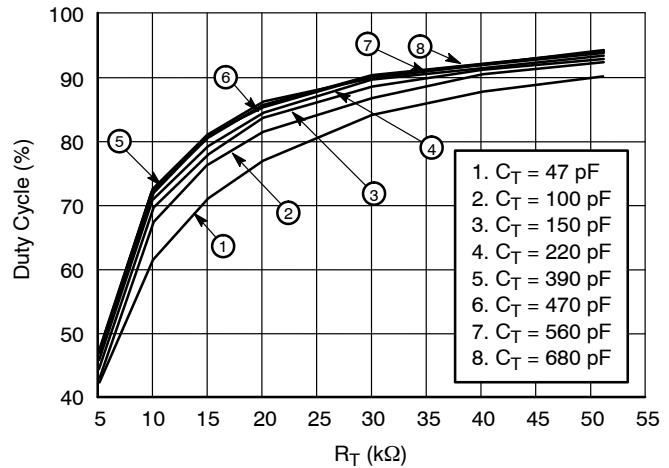

Figure 7. Duty Cycle vs. R_T for Discrete Capacitor Values

PACKAGE THERMAL DATA

| Parameter | | SOIC-16 | Unit |
|-----------------|---------|---------|---------------|
| $R_{\theta JC}$ | Typical | 28 | $^{\circ}C/W$ |
| $R_{\theta JA}$ | Typical | 115 | $^{\circ}C/W$ |

ORDERING INFORMATION

| Device | Package | Shipping† |
|----------------|----------------------|------------------|
| CS51021AEDR16G | SOIC-16 (Pb-Free) | 2500 Tape & Reel |

†For information on tape and reel specifications, including part orientation and tape sizes, please refer to our Tape and Reel Packaging Specifications Brochure, BRD8011/D.

MECHANICAL CASE OUTLINE PACKAGE DIMENSIONS

ON Semiconductor®

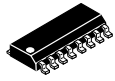

SCALE 1:1

SOIC-16 CASE 751B-05 ISSUE K

DATE 29 DEC 2006

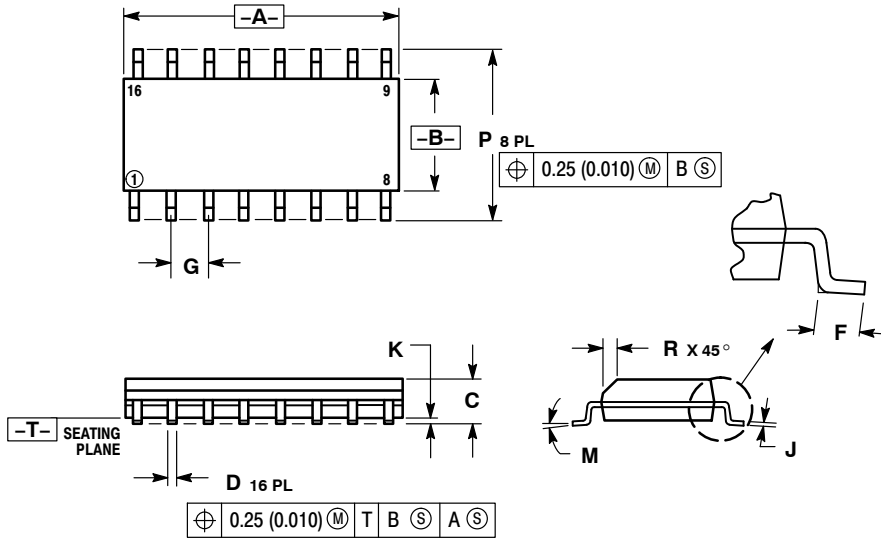

NOTES:

1. DIMENSIONING AND TOLERANCING PER ANSI Y14.5M, 1982.
2. CONTROLLING DIMENSION: MILLIMETER.
3. DIMENSIONS A AND B DO NOT INCLUDE MOLD PROTRUSION.
4. MAXIMUM MOLD PROTRUSION 0.15 (0.006) PER SIDE.
5. DIMENSION D DOES NOT INCLUDE DAMBAR PROTRUSION. ALLOWABLE DAMBAR PROTRUSION SHALL BE 0.127 (0.005) TOTAL IN EXCESS OF THE D DIMENSION AT MAXIMUM MATERIAL CONDITION.

| DIM | MILLIMETERS | | INCHES | |
|-----|-------------|-------|-----------|-------|
| | MIN | MAX | MIN | MAX |
| A | 9.80 | 10.00 | 0.386 | 0.393 |
| B | 3.80 | 4.00 | 0.150 | 0.157 |
| C | 1.35 | 1.75 | 0.054 | 0.068 |
| D | 0.35 | 0.49 | 0.014 | 0.019 |
| F | 0.40 | 1.25 | 0.016 | 0.049 |
| G | 1.27 BSC | | 0.050 BSC | |
| J | 0.19 | 0.25 | 0.008 | 0.009 |
| K | 0.10 | 0.25 | 0.004 | 0.009 |
| M | 0° | 7° | 0° | 7° |
| P | 5.80 | 6.20 | 0.229 | 0.244 |
| R | 0.25 | 0.50 | 0.010 | 0.019 |

- | | | | |
|--|--|--|--|
| <p>STYLE 1:</p> <p>PIN 1. COLLECTOR</p> <p>2. BASE</p> <p>3. EMITTER</p> <p>4. NO CONNECTION</p> <p>5. EMITTER</p> <p>6. BASE</p> <p>7. COLLECTOR</p> <p>8. COLLECTOR</p> <p>9. BASE</p> <p>10. EMITTER</p> <p>11. NO CONNECTION</p> <p>12. EMITTER</p> <p>13. BASE</p> <p>14. COLLECTOR</p> <p>15. EMITTER</p> <p>16. COLLECTOR</p> | <p>STYLE 2:</p> <p>PIN 1. CATHODE</p> <p>2. ANODE</p> <p>3. NO CONNECTION</p> <p>4. CATHODE</p> <p>5. CATHODE</p> <p>6. NO CONNECTION</p> <p>7. ANODE</p> <p>8. CATHODE</p> <p>9. CATHODE</p> <p>10. ANODE</p> <p>11. NO CONNECTION</p> <p>12. CATHODE</p> <p>13. CATHODE</p> <p>14. NO CONNECTION</p> <p>15. ANODE</p> <p>16. CATHODE</p> | <p>STYLE 3:</p> <p>PIN 1. COLLECTOR, DYE #1</p> <p>2. BASE, #1</p> <p>3. EMITTER, #1</p> <p>4. COLLECTOR, #1</p> <p>5. COLLECTOR, #2</p> <p>6. BASE, #2</p> <p>7. EMITTER, #2</p> <p>8. COLLECTOR, #2</p> <p>9. COLLECTOR, #3</p> <p>10. BASE, #3</p> <p>11. EMITTER, #3</p> <p>12. COLLECTOR, #3</p> <p>13. COLLECTOR, #4</p> <p>14. BASE, #4</p> <p>15. EMITTER, #4</p> <p>16. COLLECTOR, #4</p> | <p>STYLE 4:</p> <p>PIN 1. COLLECTOR, DYE #1</p> <p>2. COLLECTOR, #1</p> <p>3. COLLECTOR, #2</p> <p>4. COLLECTOR, #2</p> <p>5. COLLECTOR, #3</p> <p>6. COLLECTOR, #3</p> <p>7. COLLECTOR, #4</p> <p>8. COLLECTOR, #4</p> <p>9. BASE, #4</p> <p>10. EMITTER, #4</p> <p>11. BASE, #3</p> <p>12. EMITTER, #3</p> <p>13. BASE, #2</p> <p>14. EMITTER, #2</p> <p>15. BASE, #1</p> <p>16. EMITTER, #1</p> |
| <p>STYLE 5:</p> <p>PIN 1. DRAIN, DYE #1</p> <p>2. DRAIN, #1</p> <p>3. DRAIN, #2</p> <p>4. DRAIN, #2</p> <p>5. DRAIN, #3</p> <p>6. DRAIN, #3</p> <p>7. DRAIN, #4</p> <p>8. DRAIN, #4</p> <p>9. GATE, #4</p> <p>10. SOURCE, #4</p> <p>11. GATE, #3</p> <p>12. SOURCE, #3</p> <p>13. GATE, #2</p> <p>14. SOURCE, #2</p> <p>15. GATE, #1</p> <p>16. SOURCE, #1</p> | <p>STYLE 6:</p> <p>PIN 1. CATHODE</p> <p>2. CATHODE</p> <p>3. CATHODE</p> <p>4. CATHODE</p> <p>5. CATHODE</p> <p>6. CATHODE</p> <p>7. CATHODE</p> <p>8. CATHODE</p> <p>9. ANODE</p> <p>10. ANODE</p> <p>11. ANODE</p> <p>12. ANODE</p> <p>13. ANODE</p> <p>14. ANODE</p> <p>15. ANODE</p> <p>16. ANODE</p> | <p>STYLE 7:</p> <p>PIN 1. SOURCE N-CH</p> <p>2. COMMON DRAIN (OUTPUT)</p> <p>3. COMMON DRAIN (OUTPUT)</p> <p>4. GATE P-CH</p> <p>5. COMMON DRAIN (OUTPUT)</p> <p>6. COMMON DRAIN (OUTPUT)</p> <p>7. COMMON DRAIN (OUTPUT)</p> <p>8. SOURCE P-CH</p> <p>9. SOURCE P-CH</p> <p>10. COMMON DRAIN (OUTPUT)</p> <p>11. COMMON DRAIN (OUTPUT)</p> <p>12. COMMON DRAIN (OUTPUT)</p> <p>13. GATE N-CH</p> <p>14. COMMON DRAIN (OUTPUT)</p> <p>15. COMMON DRAIN (OUTPUT)</p> <p>16. SOURCE N-CH</p> | |

SOLDERING FOOTPRINT

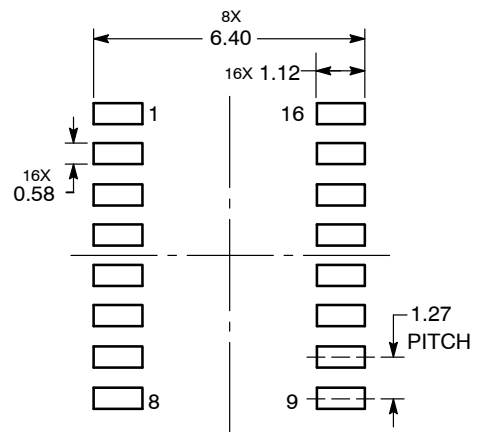

| | | |
|------------------|-------------|--|
| DOCUMENT NUMBER: | 98ASB42566B | Electronic versions are uncontrolled except when accessed directly from the Document Repository. Printed versions are uncontrolled except when stamped "CONTROLLED COPY" in red. |
| DESCRIPTION: | SOIC-16 | PAGE 1 OF 1 |

ON Semiconductor and are trademarks of Semiconductor Components Industries, LLC dba ON Semiconductor or its subsidiaries in the United States and/or other countries. ON Semiconductor reserves the right to make changes without further notice to any products herein. ON Semiconductor makes no warranty, representation or guarantee regarding the suitability of its products for any particular purpose, nor does ON Semiconductor assume any liability arising out of the application or use of any product or circuit, and specifically disclaims any and all liability, including without limitation special, consequential or incidental damages. ON Semiconductor does not convey any license under its patent rights nor the rights of others.

onsemi, **Onsemi**, and other names, marks, and brands are registered and/or common law trademarks of Semiconductor Components Industries, LLC dba "**onsemi**" or its affiliates and/or subsidiaries in the United States and/or other countries. **onsemi** owns the rights to a number of patents, trademarks, copyrights, trade secrets, and other intellectual property. A listing of **onsemi**'s product/patent coverage may be accessed at www.onsemi.com/site/pdf/Patent-Marking.pdf. **onsemi** reserves the right to make changes at any time to any products or information herein, without notice. The information herein is provided "as-is" and **onsemi** makes no warranty, representation or guarantee regarding the accuracy of the information, product features, availability, functionality, or suitability of its products for any particular purpose, nor does **onsemi** assume any liability arising out of the application or use of any product or circuit, and specifically disclaims any and all liability, including without limitation special, consequential or incidental damages. Buyer is responsible for its products and applications using **onsemi** products, including compliance with all laws, regulations and safety requirements or standards, regardless of any support or applications information provided by **onsemi**. "Typical" parameters which may be provided in **onsemi** data sheets and/or specifications can and do vary in different applications and actual performance may vary over time. All operating parameters, including "Typicals" must be validated for each customer application by customer's technical experts. **onsemi** does not convey any license under any of its intellectual property rights nor the rights of others. **onsemi** products are not designed, intended, or authorized for use as a critical component in life support systems or any FDA Class 3 medical devices or medical devices with a same or similar classification in a foreign jurisdiction or any devices intended for implantation in the human body. Should Buyer purchase or use **onsemi** products for any such unintended or unauthorized application, Buyer shall indemnify and hold **onsemi** and its officers, employees, subsidiaries, affiliates, and distributors harmless against all claims, costs, damages, and expenses, and reasonable attorney fees arising out of, directly or indirectly, any claim of personal injury or death associated with such unintended or unauthorized use, even if such claim alleges that **onsemi** was negligent regarding the design or manufacture of the part. **onsemi** is an Equal Opportunity/Affirmative Action Employer. This literature is subject to all applicable copyright laws and is not for resale in any manner.

PUBLICATION ORDERING INFORMATION

LITERATURE FULFILLMENT:

Email Requests to: orderlit@onsemi.com

onsemi Website: www.onsemi.com

TECHNICAL SUPPORT

North American Technical Support:

Voice Mail: 1 800-282-9855 Toll Free USA/Canada

Phone: 011 421 33 790 2910

Europe, Middle East and Africa Technical Support:

Phone: 00421 33 790 2910

For additional information, please contact your local Sales Representative