

THIS DRAWING IS UNPUBLISHED. RELEASED FOR PUBLICATION  
 © COPYRIGHT - By - ALL RIGHTS RESERVED.

LOC	DIST	REVISIONS					
AF	50	P	LTR	DESCRIPTION	DATE	DWN	APVD
			U	REVISED PER ECR-13-001204	19JUN13	KH	PD

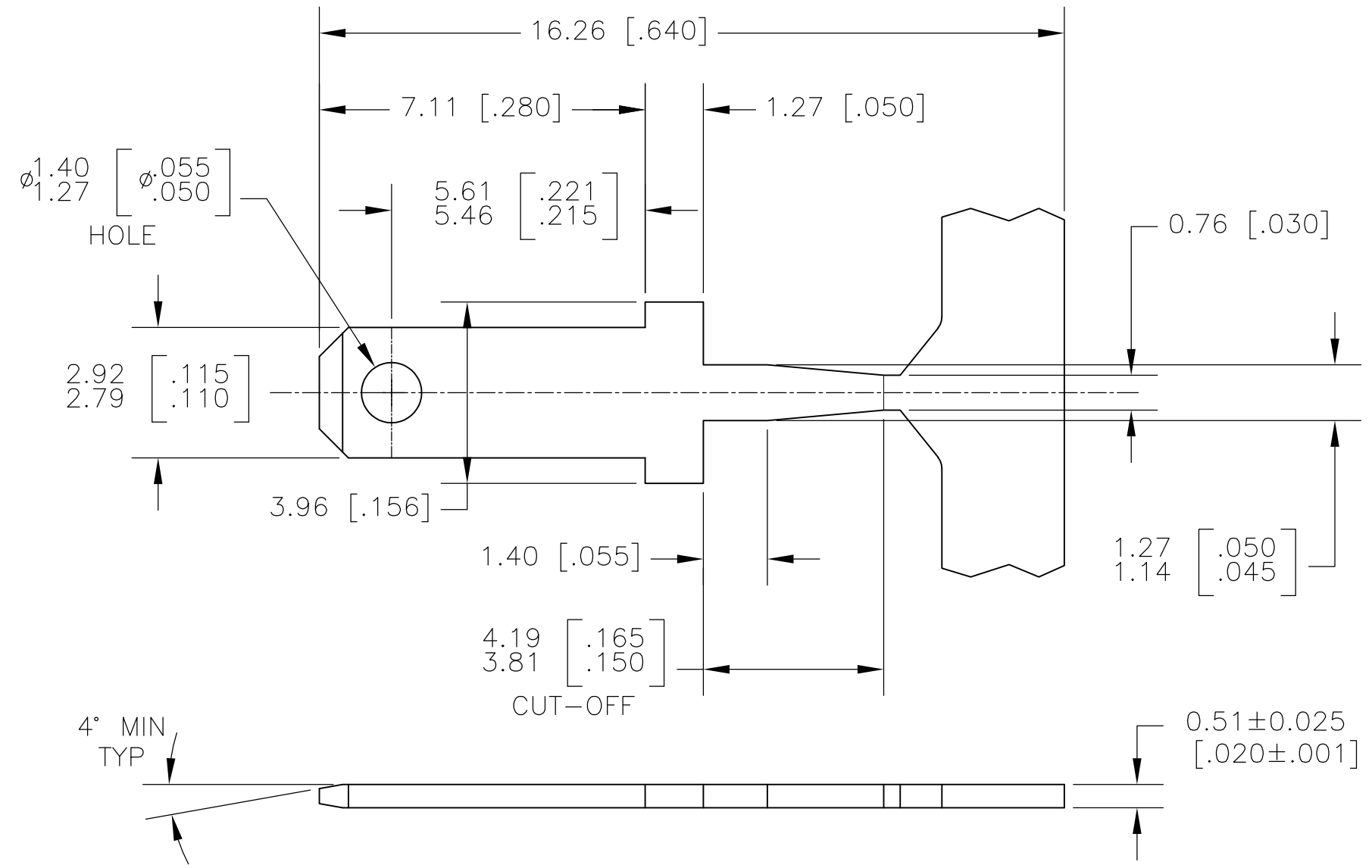

- 1 CONTINUOUS STRIP ON REELS
- 2 PART TO MEET AMP SOLDERABILITY SPEC 109-11-2 ( MILDLY ACTIVATED ROSIN)
- 3 FITS 1.22/1.11 [.048/.044] DIA HOLE IN PC BOARD. WHEN PLATED THRU HOLES ARE TO BE USED, ADJUSTMENT TO HOLE DIA'S SHOULD BE MADE TO ALLOW FOR THE PLATING.
- 4 PRELIMINARY - NOT FOR PRODUCTION, TO BE REELED ON PLASTIC REELS.
- 5 SPLICE FREE REELING.
- 6 0.00381 [.000150] MIN TIN OVER 0.00254 [.000100] MIN COPPER.
- 7 0.00381 [.000050] MIN TIN OVER COPPER.
- 8 OBSOLETE PARTS: OBSOLETE CIS STREAMLINING PER D.RENAUD/D.SINISI

8 OBSOLETE	6	5	62395-4
	6	4	62395-3
SUPERSEDED BY 62395-1	7	2	62395-2
	6		62395-1
	FINISH		PART NO.

THIS DRAWING IS A CONTROLLED DOCUMENT.		DWN	JR RUTH	12DEC00	<b>STE</b> TE Connectivity			
DIMENSIONS: MM [INCHES]		CHK	MS FEHER	12DEC00				
TOLERANCES UNLESS OTHERWISE SPECIFIED:		APVD	G PORTA	12DEC00	NAME			
0 PLC ± -		PRODUCT SPEC		TAB, FASTON, PC BOARD, 2.79 [.110] SERIES				
1 PLC ± -		APPLICATION SPEC		SIZE		CAGE CODE	DRAWING NO	RESTRICTED TO
2 PLC ± 0.25 [.010]		MATERIAL		A3		00779	C-62395	
3 PLC ± -		FINISH		CUSTOMER DRAWING		SCALE	8:1	SHEET
4 PLC ± -		SEE TABLE						1 OF 1
ANGLES ± -								REV
								U