

LOC		DIST		REVISONS			
AL	2	P	LTM	DESCRIPTION	DATE	DWN	APVD
		A9		REVISED PER ECR-17-015449	26OCT2017	BDA	KR
		B		REVISED PER ECR-20-100839	07JAN2021	PC	JS

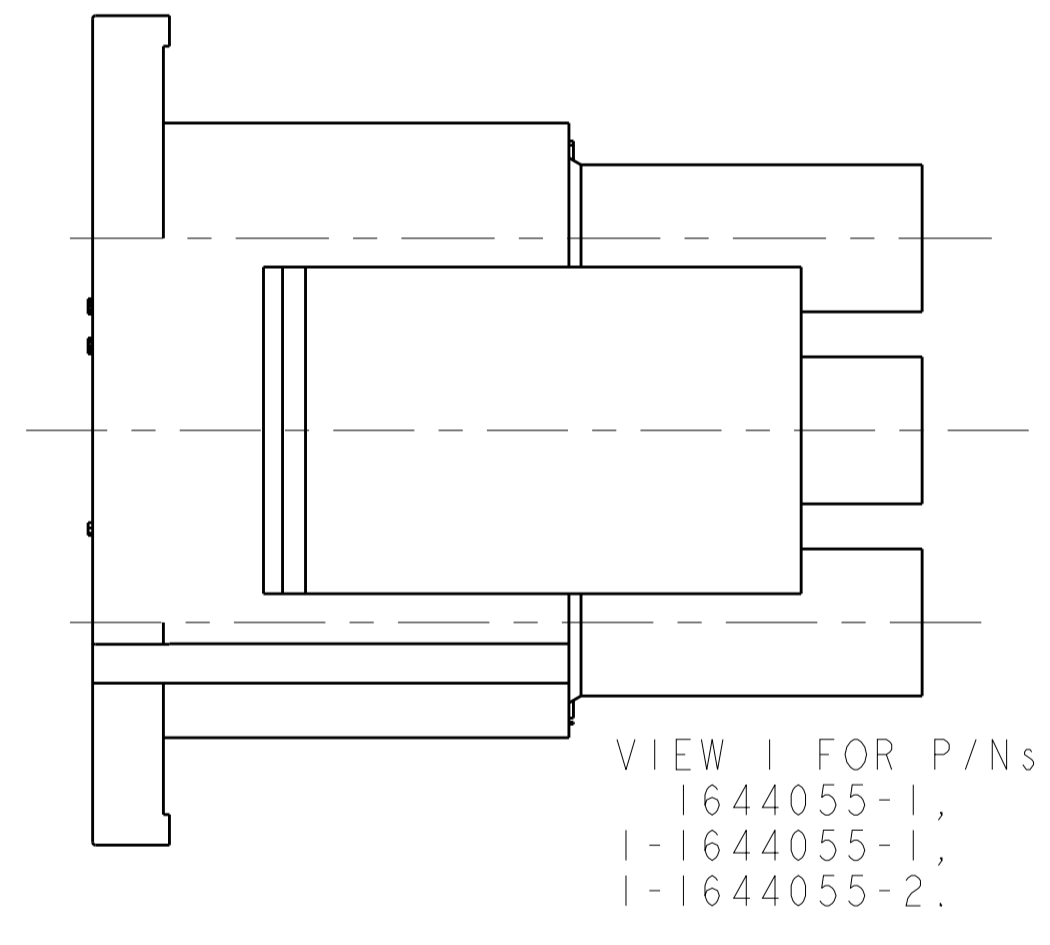

- 1. SMALL NICKS ARE PERMITTED ON THE CIRCUIT TOWERS WHICH COULD INCREASE THE INITIAL HOUSING MATING FORCE UP TO 4.4 NEWTONS (10 LBS). NO INDIVIDUAL NICKED TOWER SHALL INCREASE THIS FORCE BY OVER 2.2 NEWTONS (.5 LBS)
- 2. DIMENSIONS SHOWN REPRESENT PRODUCT IN DRY, AS MOLDED, CONDITION. ADDITIONAL 2% GROWTH DUE TO SUBSEQUENT MOISTURE ABSORPTION MAY OCCUR AND SHOULD BE ACCOUNTED FOR.

- ③ PRELIMINARY PART NOT RELEASED FOR PRODUCTION
- ④ STANDARD LATCH VERSION
- ⑤ WINDOW LATCH VERSION
- ⑥ CSA CERTIFICATION LOGO LOCATED AT LEAST ONE SIDE OF THE HOUSING, APPROXIMATELY AS SHOWN

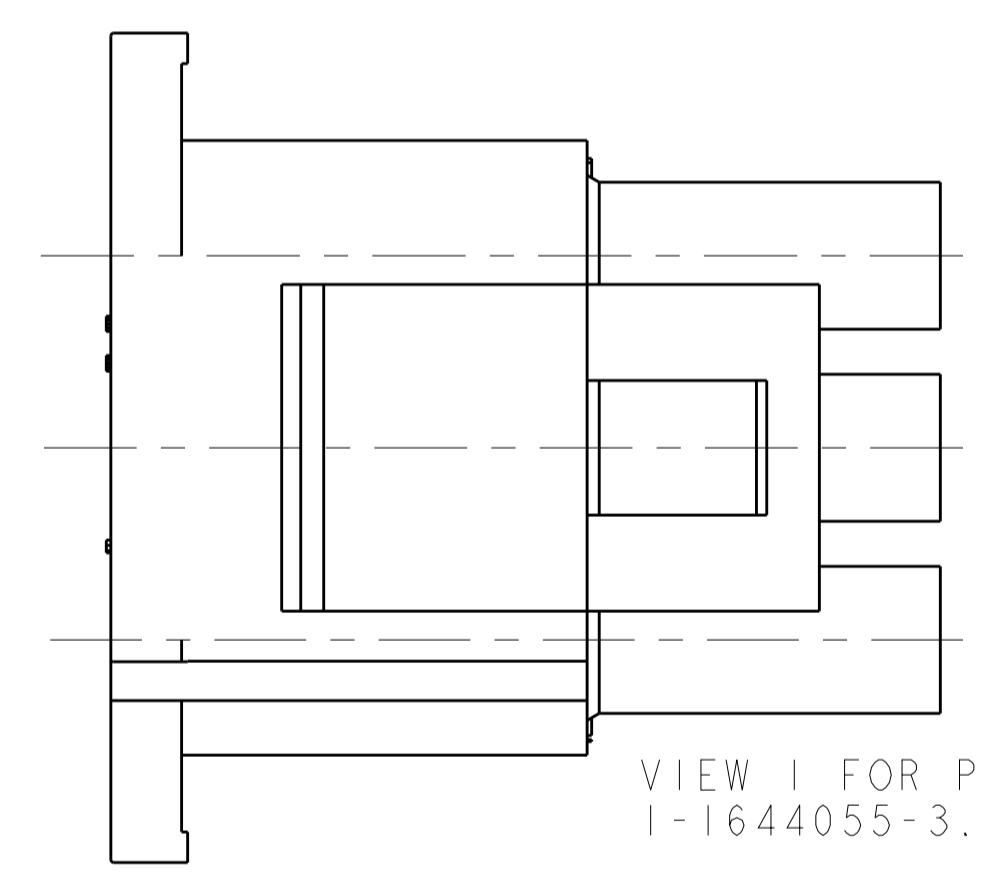
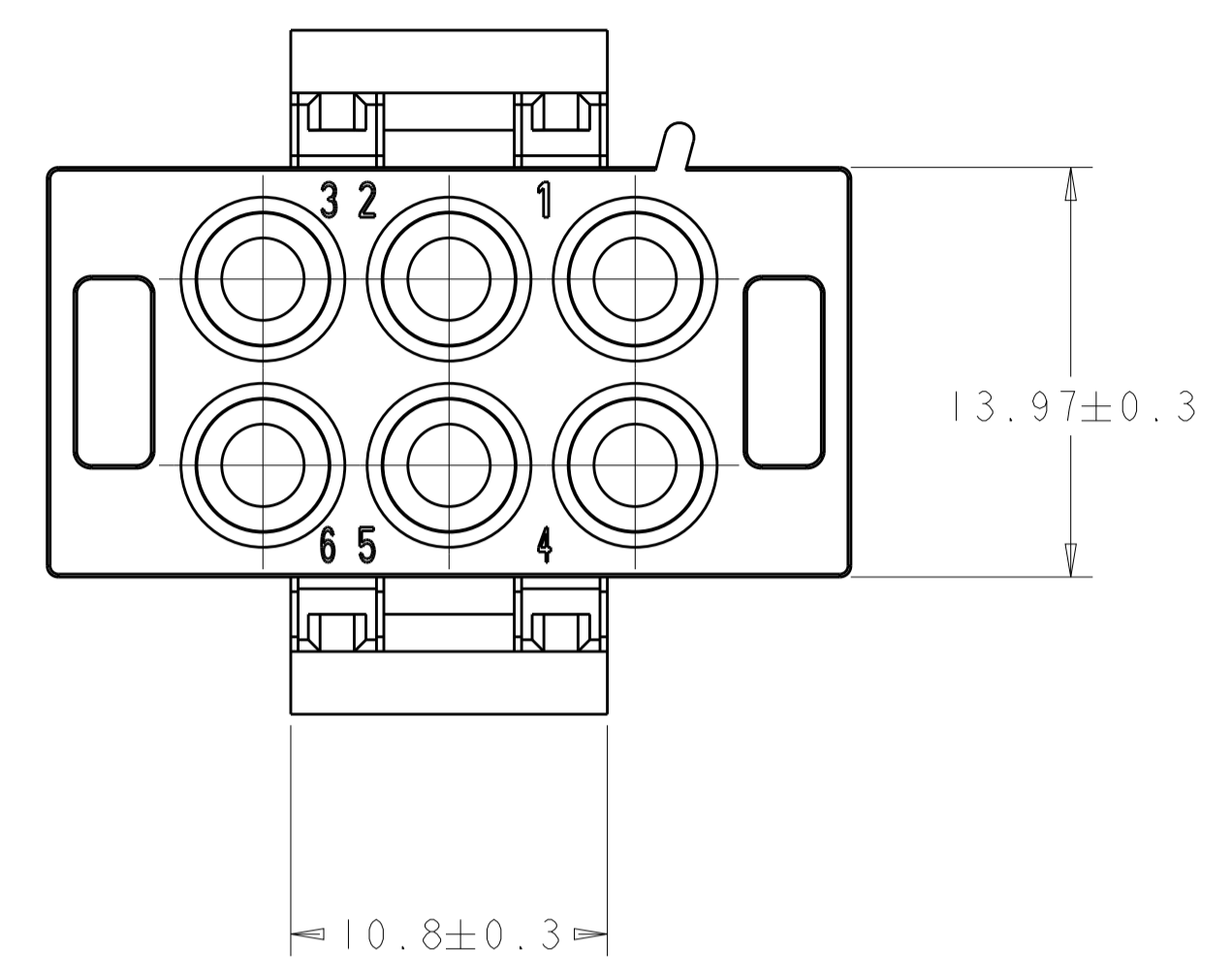
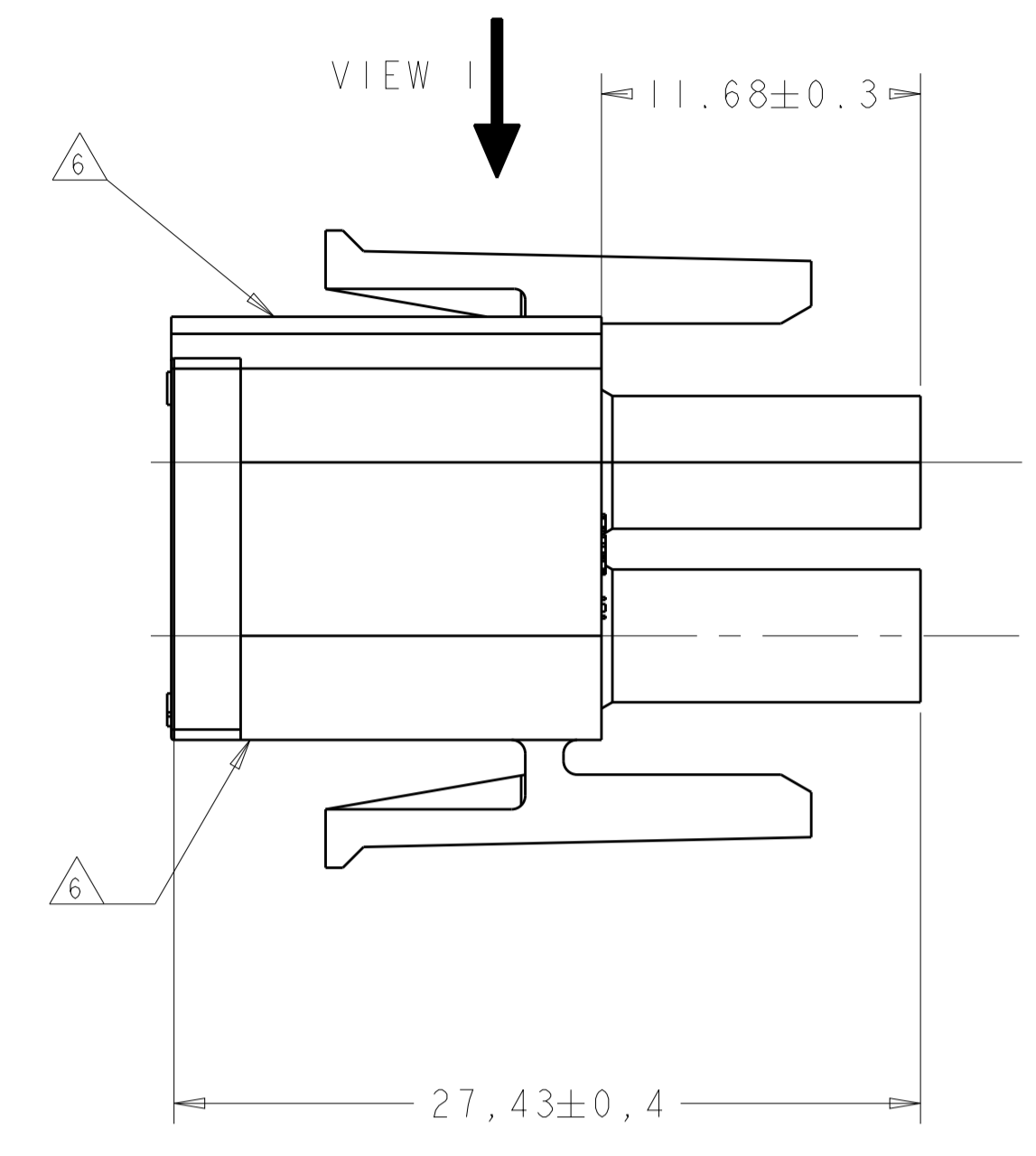
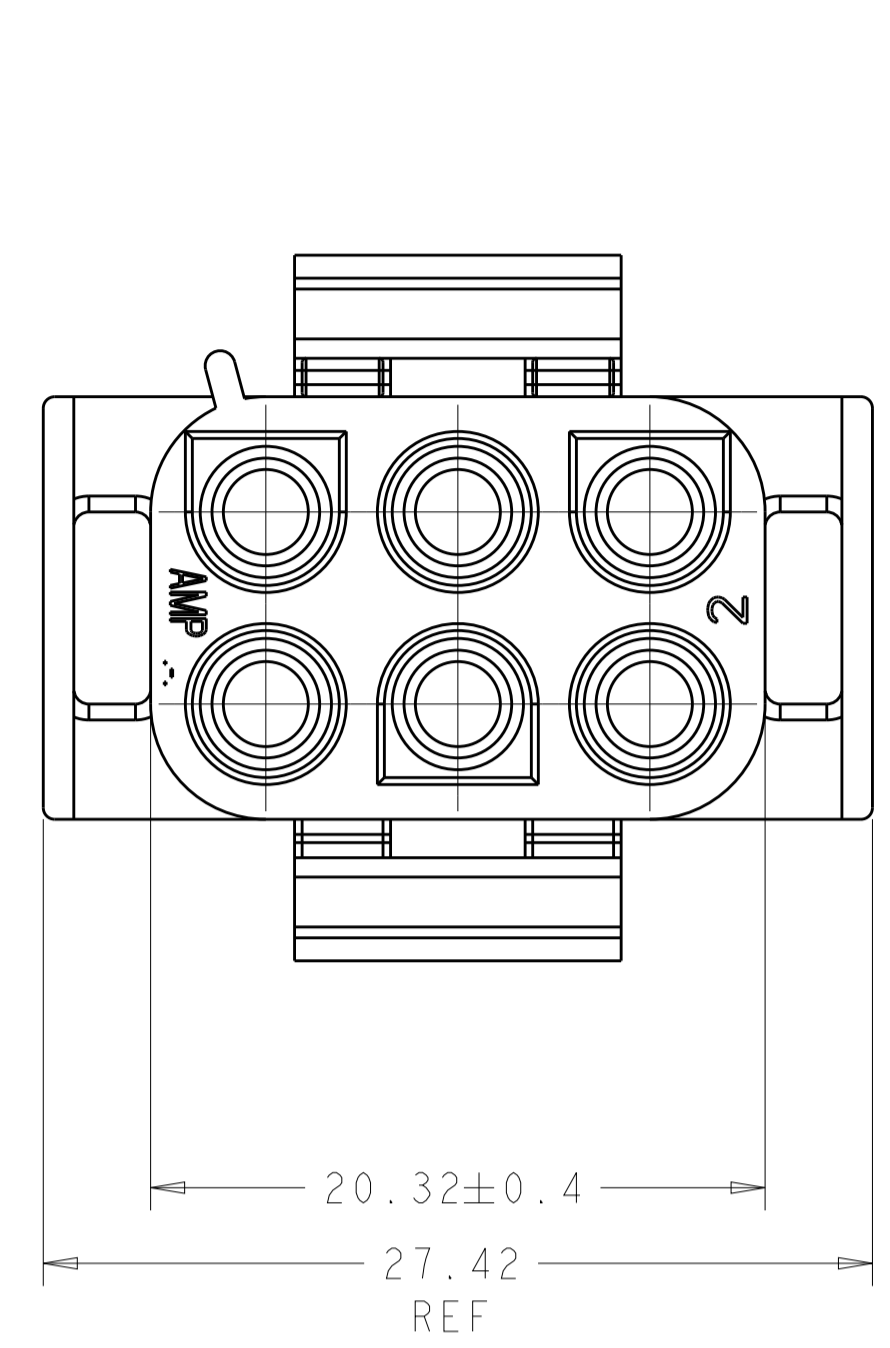
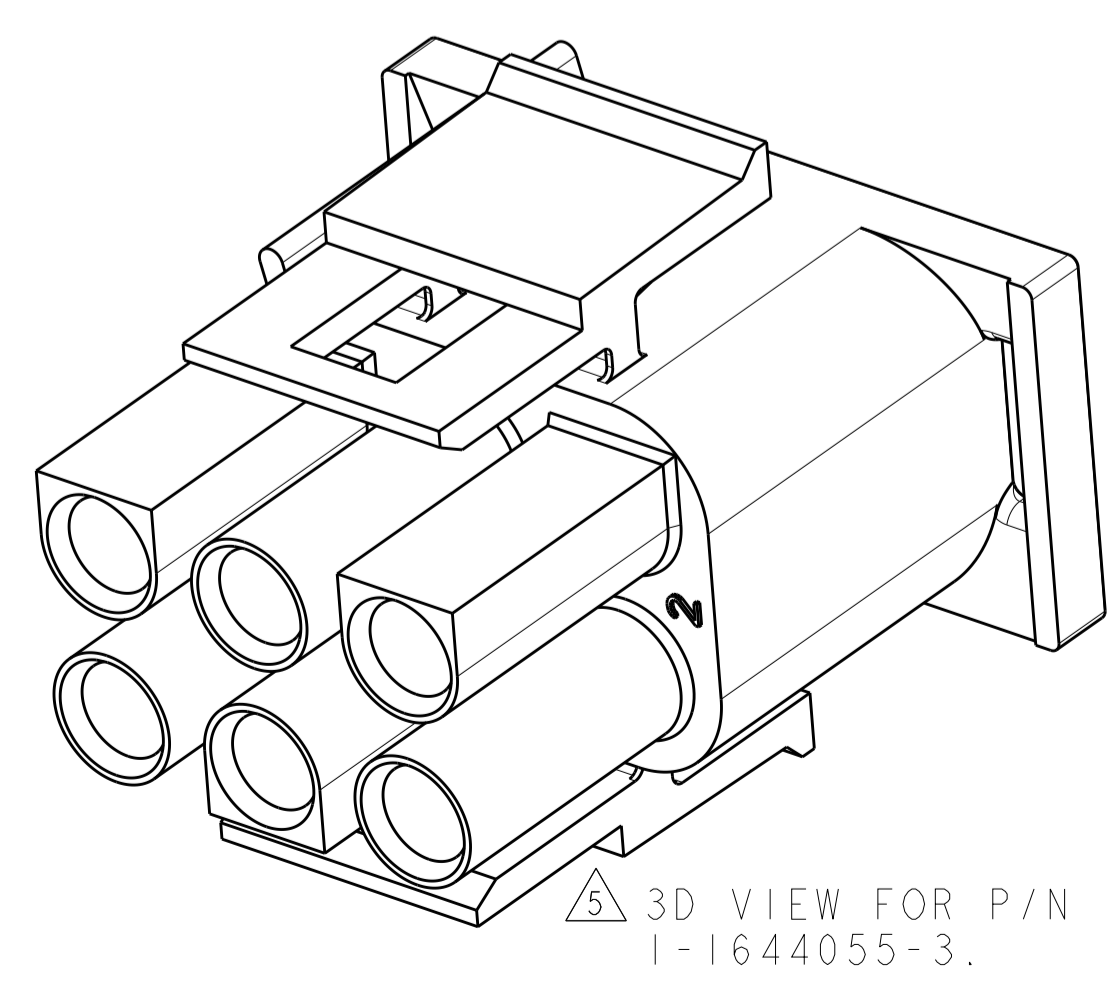

SCALE 4:1

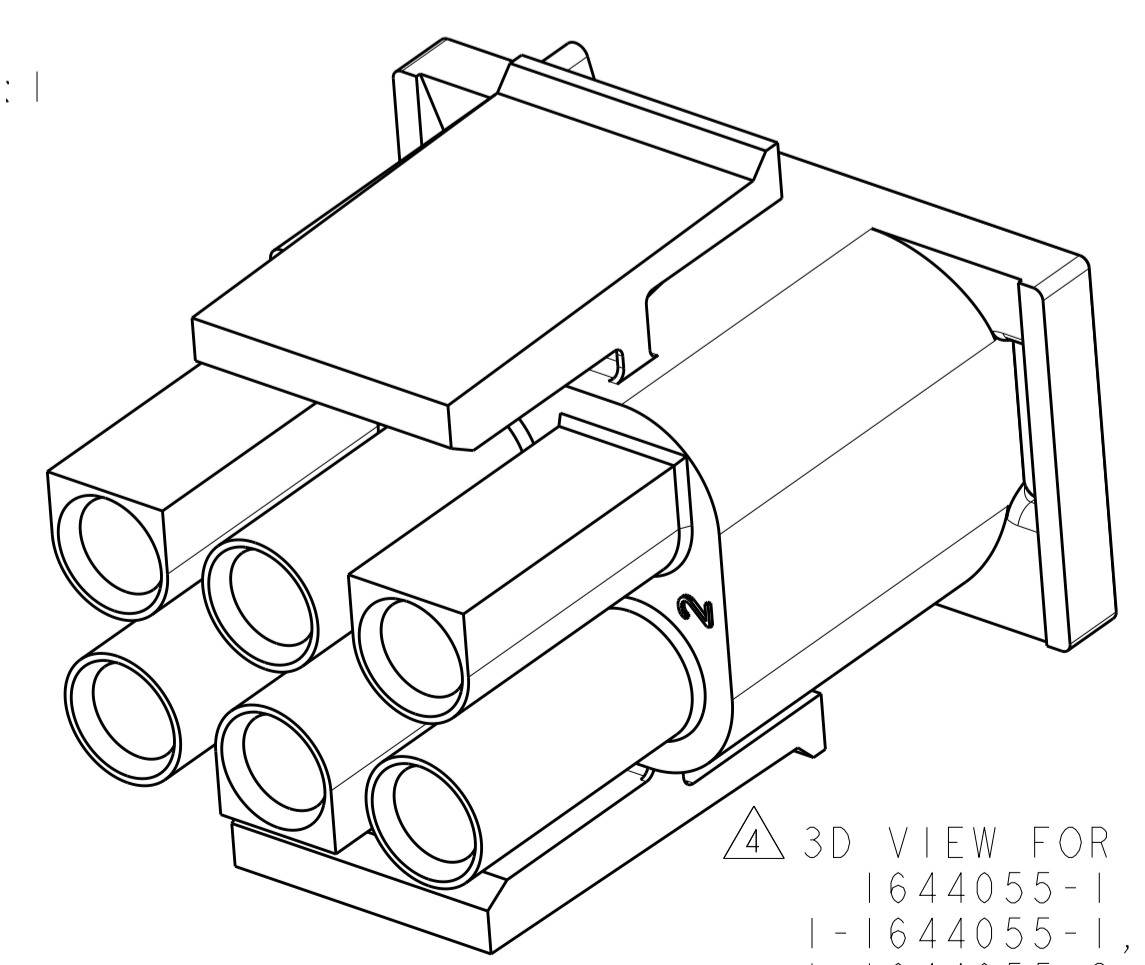

REMARK	MATERIAL	COLOUR	PN
⑤	PA66 V0 GWT 750°C WITHOUT FLAME	NATURAL	1-1644055-3 (WINDOW LATCH VERSION)
④	PA66 V0 GWT 750°C WITHOUT FLAME	NATURAL	1-1644055-2
③/④	PA6 V0	NATURAL	1-1644055-1
④	PA6 V2 GWT 750°C WITHOUT FLAME	NATURAL	1644055-1

THIS DRAWING IS A CONTROLLED DOCUMENT.		DWN: A. HERRANZ 16JAN2007	TE Connectivity
		CHK: J. SALO 23JAN2007	
DIMENSIONS:	TOLERANCES UNLESS OTHERWISE SPECIFIED:	APVD:	NAME:
mm	0 PLC ±		PRODUCT SPEC
	1 PLC ±		108-1031
	2 PLC ±		APPLICATION SPEC
	3 PLC ±		
	4 PLC ±		
	ANGLES ±		
MATERIAL:	FINISH:	WEIGHT:	SIZE: CAGE CODE: DRAWING NO:
SEE TABLE			A100779C=1644055
			CUSTOMER DRAWING